

Installation manual



Video instructions
www.duco.tv

Table of contents

01	Introduction	3
02	Regulations and safety instructions	4
03	Mounting	5
03.A	Position	5
03.B	Fixing	5
03.C	Air duct connections	6
04	Communication	7
04.A	Connection & buttons	7
05	Additional control option	9
05.A	3-position switch via Perilex (only in the Netherlands)	9
05.B	CO ₂ Box sensor	9
06	Electronical installation	11
06.A	Change settings	11
06.B	Installer / User mode	11
06.C	LED indications	11
06.D	Pairing components	12
06.E	Removing / replacing components	13
06.F	Tips	13
07	Air calibration	14
07.A	Air calibration procedure for DucoBox Reno	14
07.B	Option: installation of user controller on the DucoBox	16
07.C	Checking	17
08	Maintenance & service	18
09	Warranty	19
10	Legislation	19

Translation of the original instructions

See www.duco.eu for information regarding warranty, maintenance, technical data, etc.

Installation, connection, maintenance and repairs are to be carried out by an accredited installer. The electronic components of this product may be live. Avoid contact with water.



Vero DUCO - Handelsstraat 19 - 8630 Veurne - Belgium
tel +32 58 33 00 33 - info@duco.eu - www.duco.eu

DUCO

01 Introduction

The DucoBox Reno, the most compact ventilation unit in Europe, performs two functions in a DUCO Demand-Controlled Natural Ventilation System.

On the one hand, it is the controller, or brain of the system. It receives and interprets signals from components (measurements from sensors or manual input), on the basis of which it controls the ventilation system.

On the other hand, it is the extractor fan that exhausts stale air with excessive CO₂ content or humidity.

CO₂ levels are measured via optional CO₂ sensors; the humidity level is measured via a standard RH sensor integrated in the box itself.

DUCO advises against connecting the DucoBox (via a duct or directly) to an extractor hood, regardless of the type. This usually causes excessive fouling in the DucoBox, which affects its operation or has a more direct effect on output.

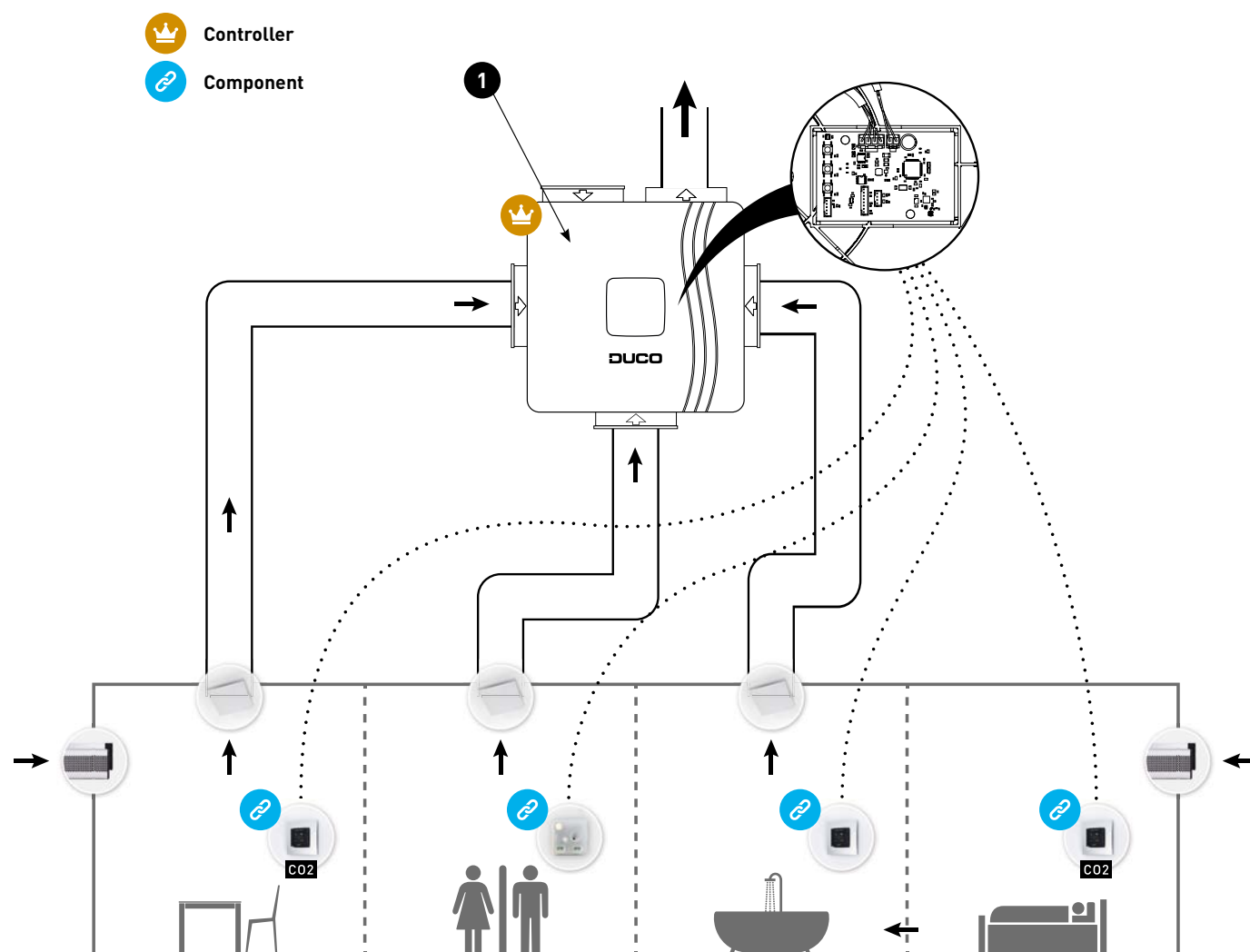

Figure 1: with standard integrated RH sensor

02 Regulations and safety instructions



The installer is responsible for installing and commissioning the unit.



Do not install this product in areas where the following are present or could occur:

- Excessively greasy atmosphere.
- Corrosive or flammable gases, liquids or fumes.
- Room air temperature above 40 °C or below -5 °C.
- Relative humidity higher than 90 % or outdoors.
- Obstacles that prevent access to or the removal of the fan unit.
- Bends in the ducts immediately upstream of the fan unit.
- The DucoBox Reno must not be connected to a (motorless) extractor hood or tumble dryer.

Take care to ensure that the electrical power supply is a 230 V, single-phase earthed 50/60 HZ, AC system. The device must be connected to a fused wall socket. Preferably mount the unit in an enclosed space. The fan unit can only be used with the appropriate DUCO accessories and user controller(s). The installer must ensure that the fan unit is positioned at least 3 m away from a chimney pipe. The unit must not be used in locations where it could be subjected to direct water spraying. Certain situations may require the use of acoustic insulation materials. Check that the unit is complete and undamaged when you take it out of the packaging. If in doubt about this, contact DUCO / your DUCO distribution point.

Electrical equipment should be handled with care.

- Never touch the unit with wet hands.
- Never touch the unit when barefoot.

Do not use the unit in the presence of flammable or volatile substances such as alcohol, insecticides, petrol etc. Make sure that the electrical system to which the unit is connected, complies with the stipulated conditions. Do not expose the device to weather conditions. Do not place any objects on the unit. Do not use the unit as an extractor for water heaters, heating systems, etc. Ensure that the unit discharges into a single exhaust duct that is suitable and installed for the purpose and exhausts to the outside. Ensure that the electrical circuit is not damaged. Always observe the safety instructions in the manual when installing the unit. Failure to adhere to these safety instructions, warnings, notes and instructions could result in damage to the DucoBox Reno or in personal injury for which DUCO NV cannot be held liable. The DucoBox Reno requires to be installed in accordance with the general and locally applicable construction, safety and installation regulations of municipal and other authorities. Only an accredited installer is permitted to install, connect and commission the DucoBox Reno, as described in this manual. Keep the manual close to your unit. Maintenance instructions must be followed closely in order to avoid damage and/or wear. It is recommended that a maintenance contract be taken out to ensure the unit is regularly inspected and cleaned. The device must be fitted in a touch-safe manner.

This means, among other things, that under normal operating conditions no-one can reach moving or electrically live parts of the fan without intending to do so for operations such as:

- Taking off the lid.
- Taking the motor module out of the fan after removing the lid.
- Disconnecting a duct or control valve from the connection opening during normal operation.

It must not be possible to touch the fan by hand. Ducting must therefore always be connected to the DucoBox Reno before it is put into operation. Therefore, at least 900 mm of ducting must be connected to the unit. The DucoBox Reno satisfies the legal requirements imposed on electrical equipment. Always ensure that before work begins, the device is isolated from the power supply by removing the power cord from the wall socket or by switching off the fuse. (Use a measuring instrument to check that this is actually the case!) Use suitable / appropriate tools to work on the unit. Use the unit only for applications for which it has been designed, as stated in this manual. The ventilation unit should operate permanently, i.e. the DucoBox Reno must never be switched off (legal obligation). The electronic components of the ventilation unit may be live. In the event of a fault, contact a professional installer and have repairs carried out only by qualified personnel. This unit is not intended for use by people (including children) with reduced physical, sensory or mental capabilities, or who lack experience of know-how, unless they are supervised or have been given instructions on the use of the unit by a person who is responsible for their safety. Children must be supervised to ensure that they do not play with the unit. If the power cord is damaged, it must be replaced by the manufacturer, after-sales support or individuals with comparable qualifications in order to prevent any hazard. The user is responsible for safely removing the ventilation unit at the end of its service life, in accordance with locally applicable laws or regulations. You can also take the unit to a collection point for used electrical equipment. The unit is only suitable for residential construction and not for industrial use, such as swimming pools and saunas. When handling electronics, always take ESD¹ inhibiting measures, such as wearing a grounded wristband. Modifications to the unit or to specifications stated in this document are not permitted. Do not pull on the cord to remove the plug from the socket. Always consult the installer of your combustion appliance to establish whether there is any risk of flue gases entering the home. Check that the voltage shown on the type plate matches the local mains voltage before connecting the unit. You will find the type plate inside the box.

1 ESD = electrostatic discharge

03 Mounting

03.A Position

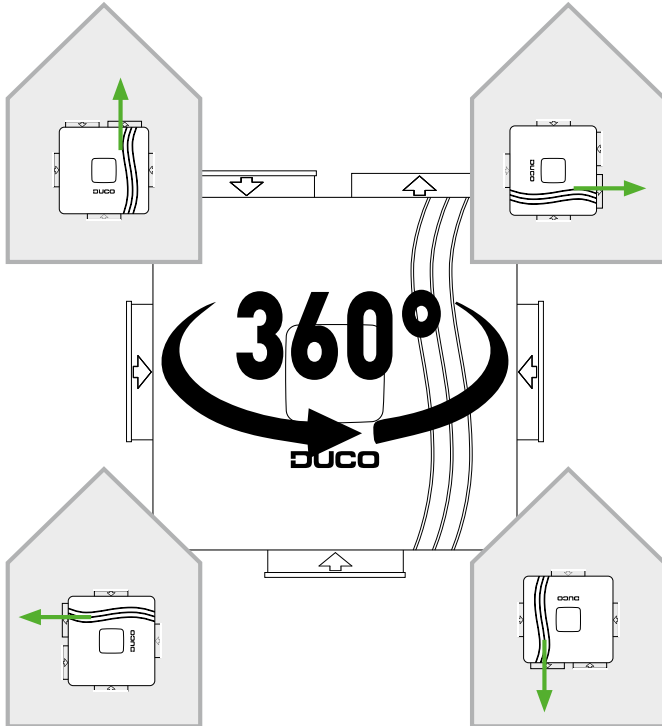

figure 2: Against a wall, you can position the Box in any possible direction.

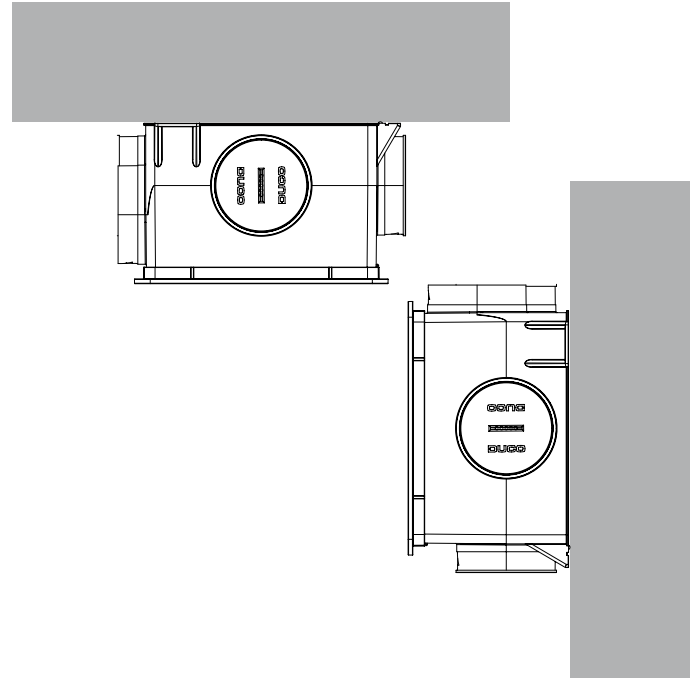

Figure 3: You can mount the box vertically or horizontally.

If you place the DucoBox Reno in a damp room with a water connection, avoid placing it on the floor.

03.B Fixing

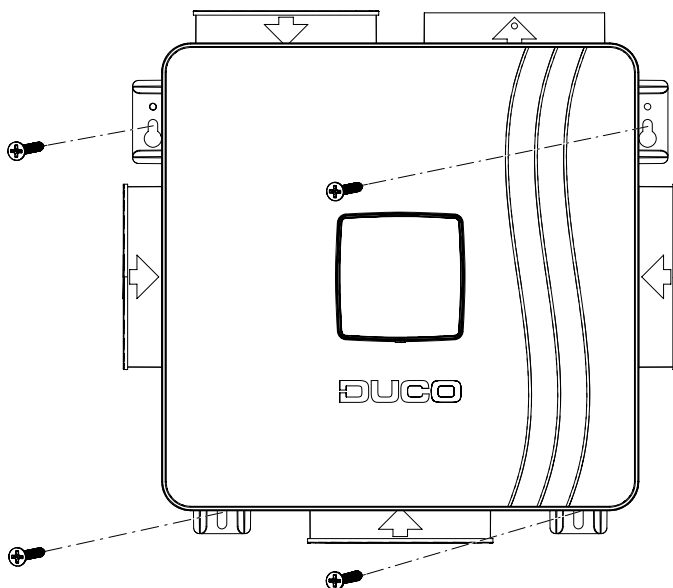

Figure 4: Mounting: adapt the mounting material to the surface

03.C Air duct connections

Limit the resistance. A non-return flap is required when discharging into a manifold.

Be sure to take note of the '10 unmissable tips' as well when mounting the DucoBox. Avoiding excessive use of bends, especially angles greater than 90° and adhering to the diameter guidelines for the ductwork will ensure that the ventilation box is able to do its job satisfactorily. Failure to take account of this recommendation may result in a highly energy and maintenance intensive system that gives rise to excessive noise nuisance frequently.



10 UNMISSABLE TIPS



The proper functioning of your DUCO ventilation system depends entirely on the choice and quality of the exhaust duct system!

Has the duct system been optimized? Seek professional advice from your duct supplier. It saves you time, guarantees quality and provides an energy benefit for the end user!

DISCLAIMER: no rights can be derived from this document. All tips are advisory only. Each contractor may determine at their own discretion which tips are feasible and/or useful, depending on the project.

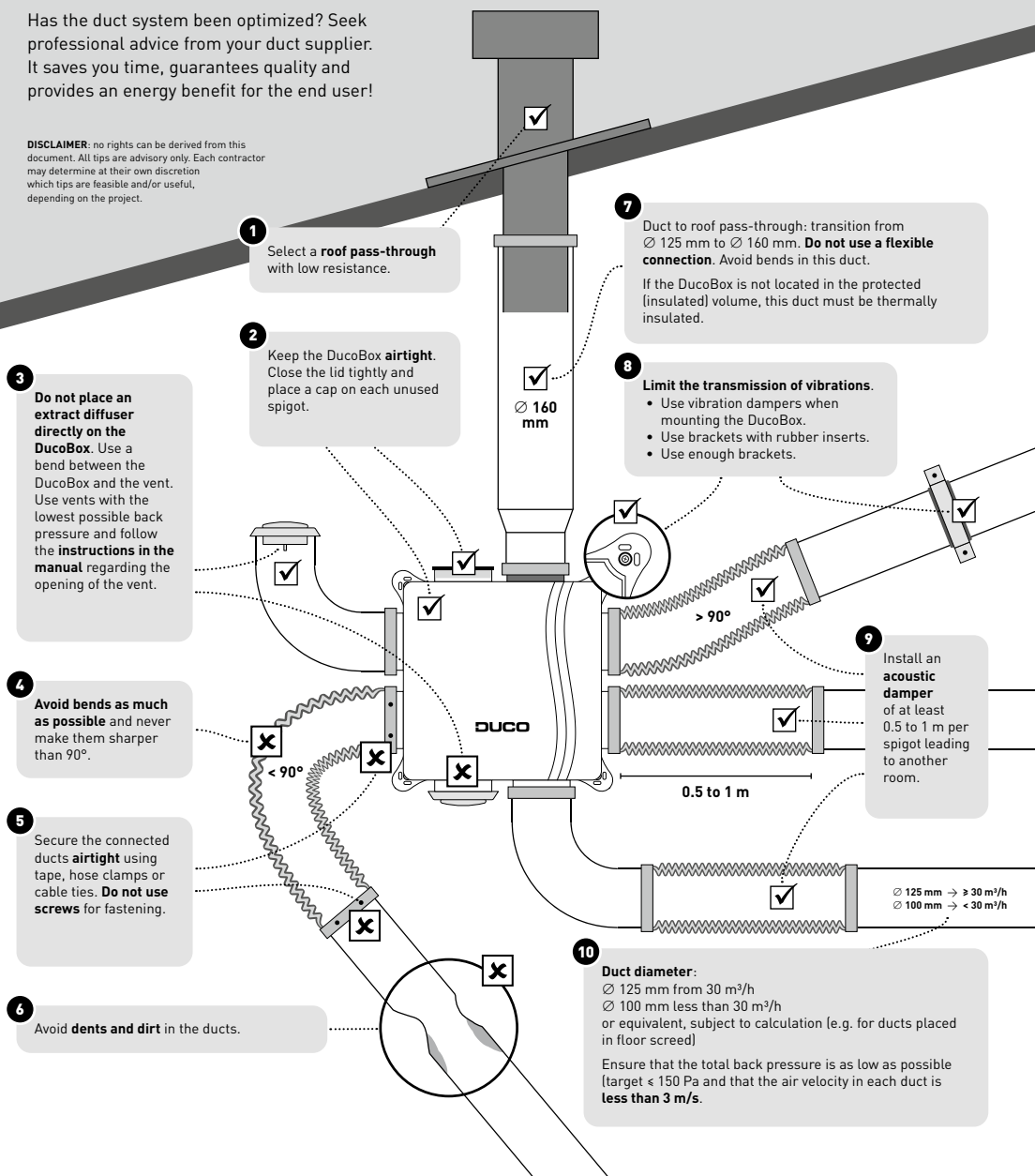

04 Communication

04.A Connection & buttons

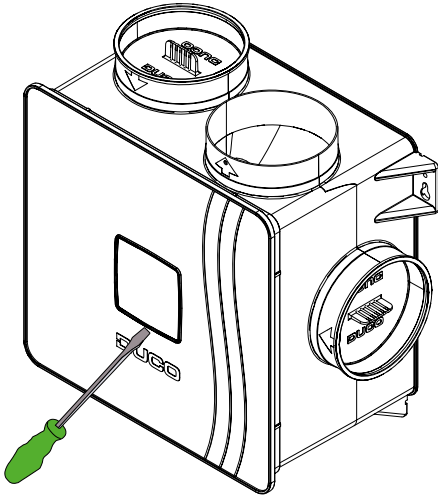

Figure 5: Remove the cover plate of the lid with a screwdriver to gain access to the adjustment buttons.

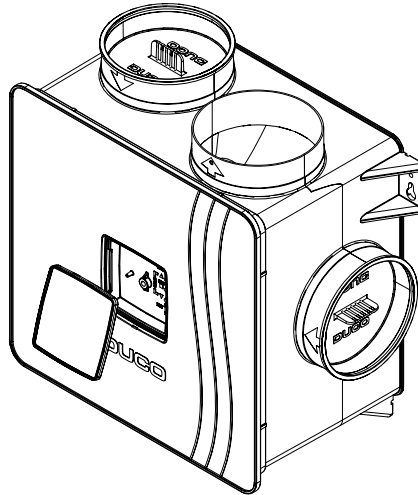

Figure 6: You now have access to the adjustment buttons.

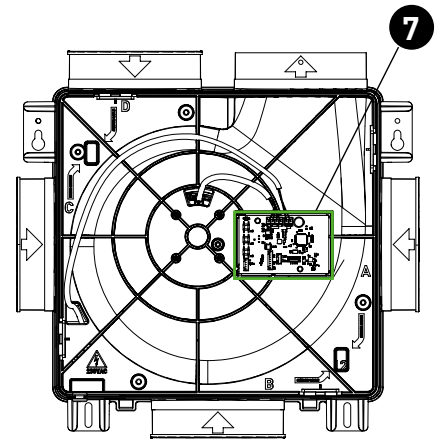

Figure 7: The circuit board is located under the lid.

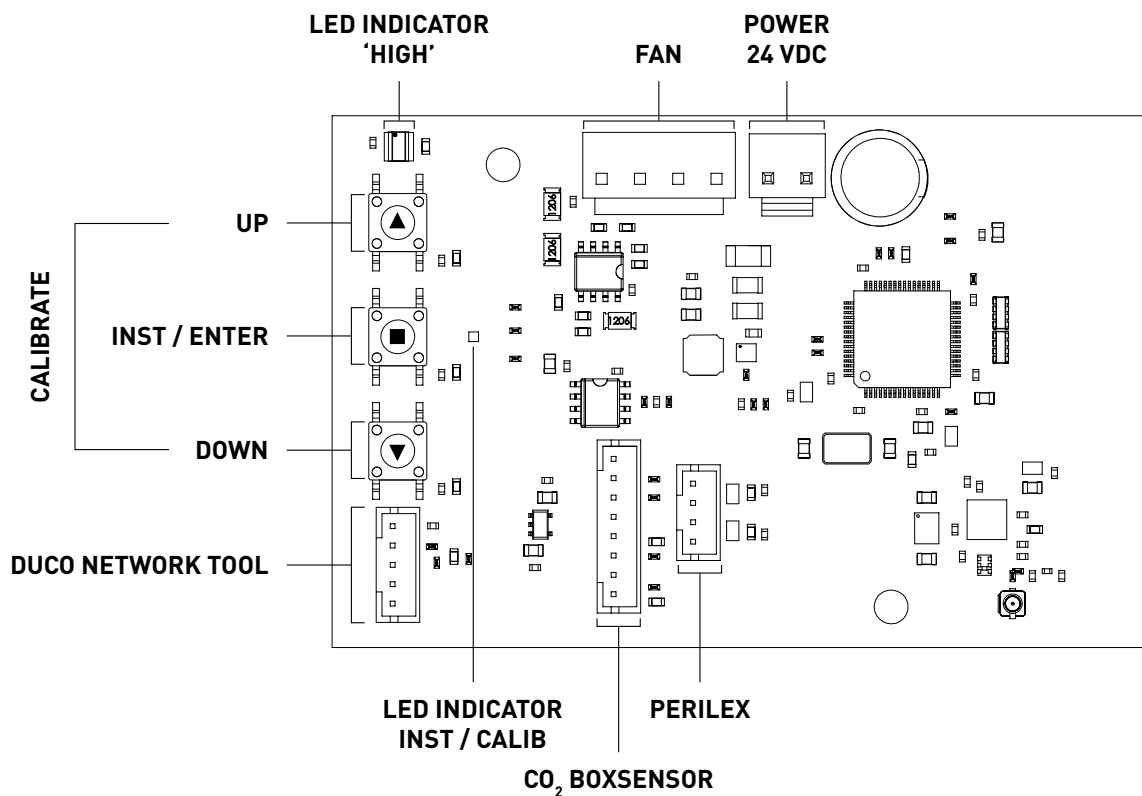

Figure 8: Connections and buttons on the circuit board of the DucuBox Reno

Wireless communication

The DucoBox Reno is able to communicate with DUCO components via a wireless (RF) connection.

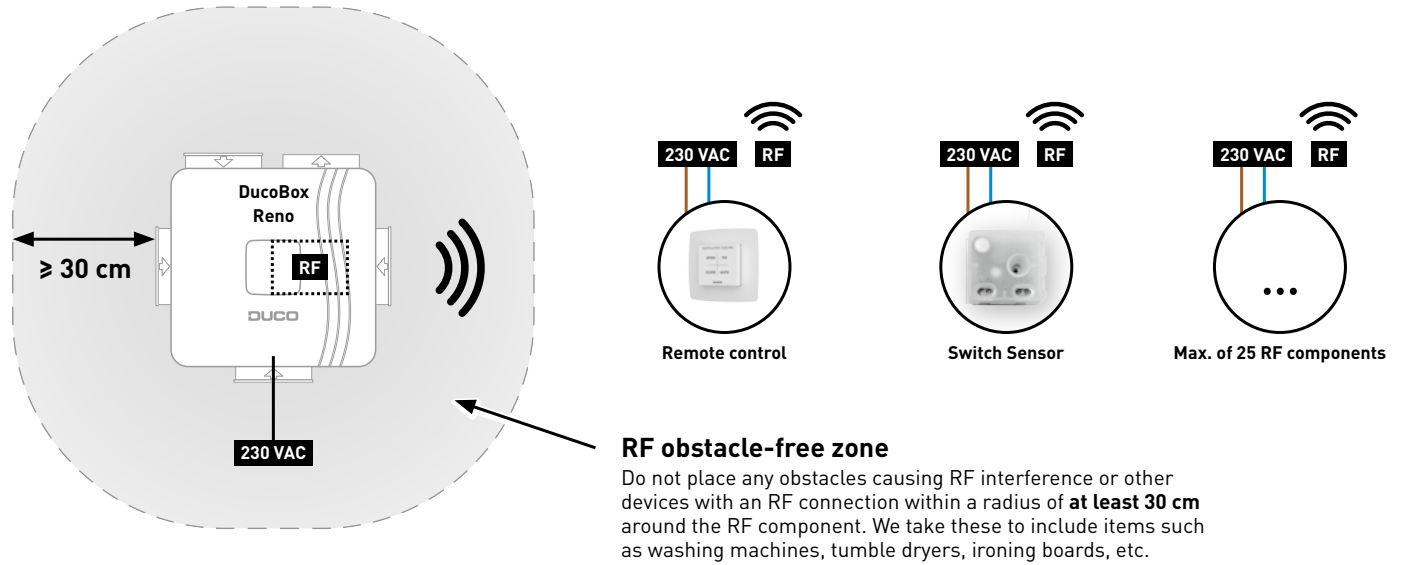

Figure 9: Communication via RF

RF components have a maximum free-field range of 350 metres. This distance will be much less in a building because of obstacles. Therefore, you will need to take objects such as walls, concrete and metal into account. All components (except those which are battery powered) also act as repeaters. Signals from components that are unable to make a (strong) connection with the controller are forwarded automatically via no more than one other non-battery-powered component (= hop). Please refer to the information sheet RF communication (L8000018) at www.duco.eu for further information.

DUCO RF	
Power supply	230 VAC
Wiring	1,5 mmm2
Frequency	868 Mhz
Maximum distance	350 m, free field (less through obstacles)
Maximum number of components	Up to 25 wireless components in a single system

05 Additional control option

05.A 3-position switch (only in the Netherlands)² through Perilex

The last action on any user controller is always leading. The ventilation position on the 3-position switch can therefore be overruled by another user controller, such that an incorrect ventilation position will be visible on the 3-position switch.

Please refer to the manual with the DUCO Perilex plug for more information.

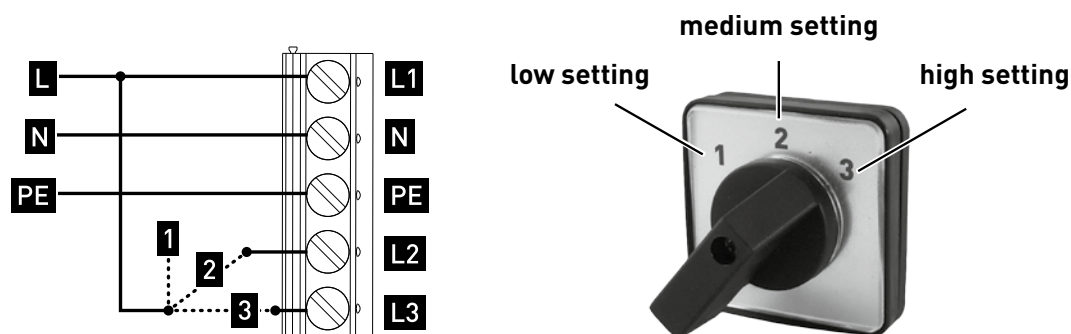

Figure 10: Perilex switch

05.B CO₂ Box sensor

A CO₂ Box sensor can be integrated into a duct port of the DucoBox Reno and provide measurement in an air duct. A DucoBox Reno can contain **a maximum of one CO₂ Box sensor**.



Video instructions
www.duco.tv

CO₂ BOX SENSOR MOUNTING + CONNECTING

1. Disconnect the DucoBox Reno from the mains and remove the lid of the DucoBox Reno. To do this, first remove the screw located behind the cover plate. (Figure 11: Remove the cover plate and unscrew the lid).
2. Disconnect the motor plate by unclipping the 4 clamps. To do this, slide a flat screwdriver behind the clamp and tilt it back slightly (approx. 5mm) so that the clamp is released from the opening in the casing (see Figure 11: open the casing and Figure 12: remove the motor plate).
3. Secure the CO₂ Box sensor from the outside in the desired duct port by clicking it into place on the rib closest to the motor plate (Figure "Figure 14: snap the CO₂ box sensor into the duct port" on page 10: Clicking the CO₂ Box sensor into the duct port). To do this, make a tilting movement by first tightening the lower and then the upper clamp.
4. Pass the cable of the CO₂ Box sensor through the opening on the inside of the casing at the level of the corresponding duct port. Then pass the cable of the CO₂ Box sensor through the relevant opening (marked with 'sensor cable') of the motor plate according to the diagram shown below in Figure 14: four options for wiring a maximum of 1 CO₂ Box sensor to the circuit board.
5. Attach the motor plate to the casing. The motor plate is fixed when the 4 clamps are engaged in the casing. Make sure that the strain relief of the power cable is pushed into the opening provided for this purpose. The power cable can be attached to the outside of the casing by using the cable clips.
6. Connect the CO₂ Box sensor to the connector (CO₂) on the DucoBox Reno PCB (04.A).
7. Mount the lid correctly on the unit. Make sure the notch in the lid is over the power cable opening ("Figure 16: Note the recess in the lid" on page 10: Note the notch in the lid). Screw the lid back on and close with the cover plate.

² This is not a DUCO component.

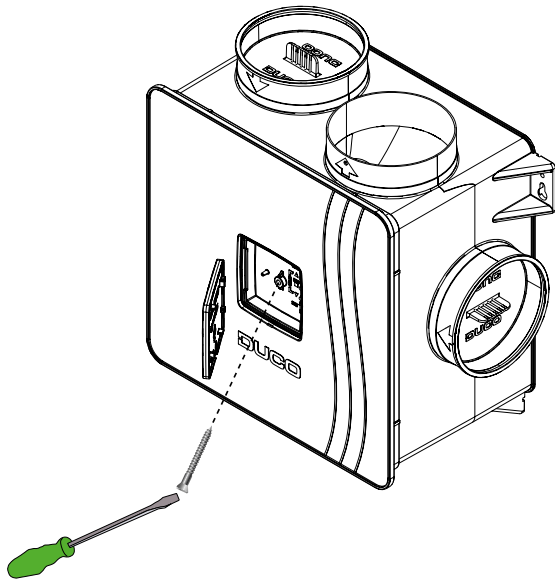

Figure 11: remove the cover plate and unscrew the lid

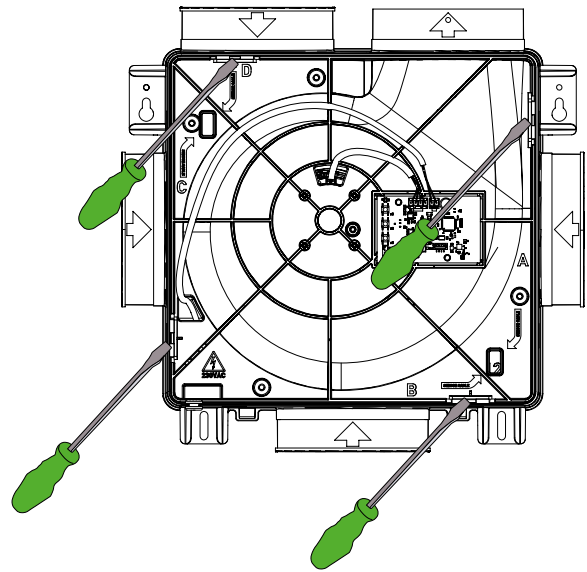

Figure 12: detaching the motor plate

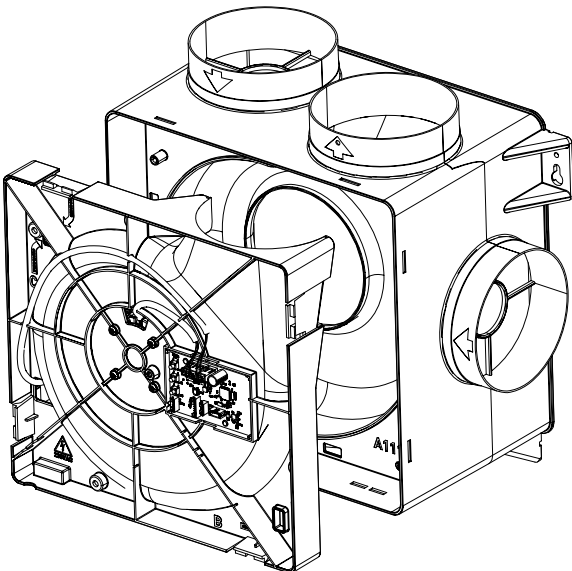

Figure 13: removing the motor plate

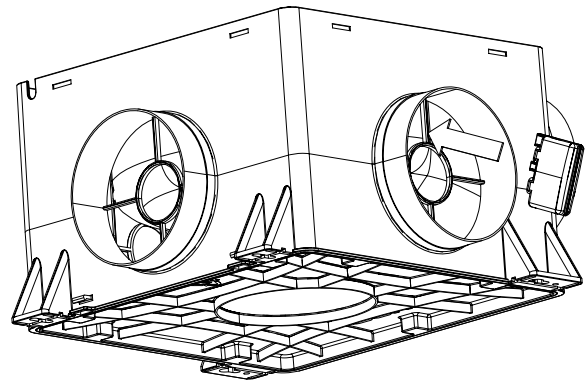

Figure 14: snap the CO₂ box sensor into the duct port

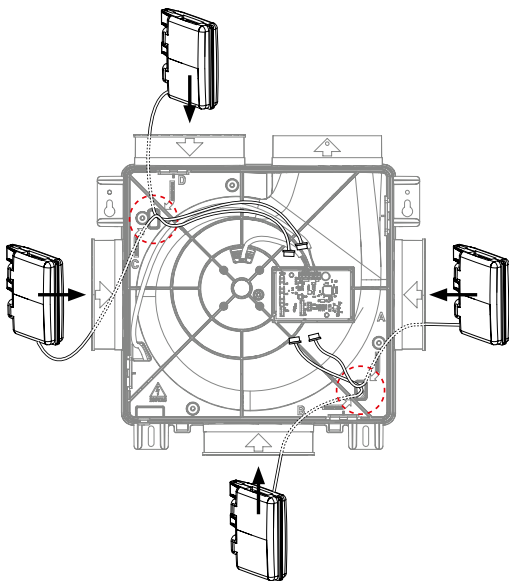

Figure 15: Four options for cabling up to one CO₂ Box sensor to circuit board

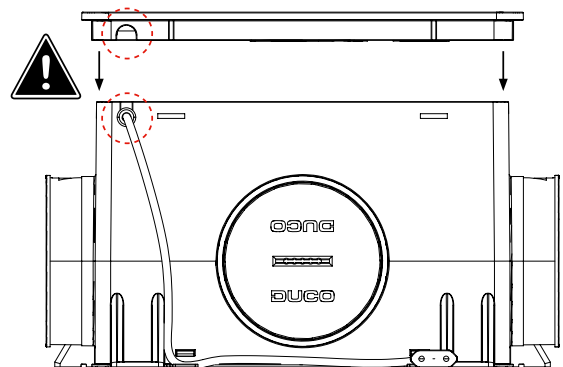

Figure 16: Note the recess in the lid

06 Electrical installation

06.A Change settings







Most of the factory settings for the network and components will be satisfactory as they are, however, depending on the situation, it may be desirable to change some parameters, such as the CO₂ setpoint. This can be done using the DUCO Network Tool.³ This user-friendly software also enables problems in the system to be pinpointed. The DUCO Network Tool is issued to every installer after attending a free training course at the DUCO Academy⁴. Please refer to our website or your DUCO dealer for further information.

06.B Installer / User mode

To add, remove or replace components to the network, the system should be put in 'Installer mode'. The LED on each component indicates the component's active mode (see table at 06.C in the next section).

Installer mode can be activated by pressing the INST button of the DucoBox Reno (see drawing in chapter "04.A Connection & buttons"). When the LED on the controller starts flashing green, Installer mode is active. Press INST again to return to User mode (LED fully on or off). The system reverts automatically to User mode after 15 minutes of inactivity.

06.C LED indications

	RED (blinking slowly) Not in network	RED (blinking rapidly) Busy pairing
	GREEN (blinking slowly) In network	GREEN (blinking rapidly) In network, waiting for associated components
	YELLOW (clignotement rapide) Transitional phase (please wait)	YELLOW (on) Initialising (system configuration in progress)
	WHITE or OFF Normal	
	BLUE Visualisation of component when changes are made via the controller.	
	ORANGE The system is not working correctly because the DucoBox has not been calibrated. Restart the DucoBox. Follow the guidelines in '10 essential tips' if the problem recurs continually.	

3 Only in Belgium and the Netherlands

4 Only in Belgium and the Netherlands

06.D Pairing components

Never pair more than one system with RF components at the same time. If you do so, a component in the wrong network could be paired, e.g. in the neighbours' DucoBox.

PAIRING COMPONENTS ON THE DUCOBOX RENO

1. Activate 'Installer mode' by tapping 'INST' on the DucoBox. The LED will flash green rapidly.
2. Add control components by tapping once on the component to be paired. The LED will flash red briefly and then start to flash green rapidly. Repeat this step until all remaining components in the current zone have been paired. For RF components: start with the closest component to the controller. If the first pairing is unsuccessful, another component may be tried first, which can then act as a hop for components that are unable to make an RF connection with the DucoBox.
3. Once all components have been paired, 'Installer mode' can be deactivated by tapping 'INST' on the DucoBox Reno. The LEDs on all components will stop flashing.

Example of a pairing sequence

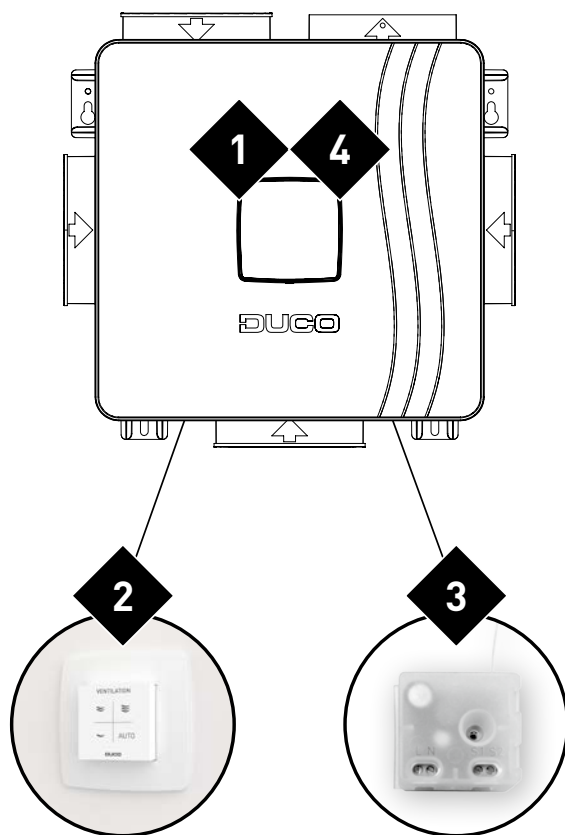



Figure 17:  indicates the order in which to press a component button

06.E Removing / replacing components

Removing paired components from the network or replacing is only possible within 30 minutes after the component is paired in or is restarted. Restarting can be done by disconnecting the power for a moment. After a time-span of 30 minutes, remove and replace operations are ignored.

Removing a component

1

Activate 'Installer mode' by **long-pressing 2 diagonal buttons on a paired user controller**. The LED will flash green rapidly.

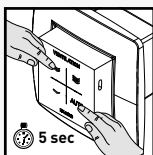

2

Press **once and hold** a button on the component to be removed in order to remove it from the network.
ATTENTION: any underlying components will also be removed from the network.

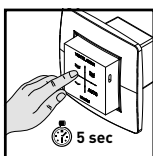

3

Deactivate 'Installer mode' by pressing the 4 buttons on a **paired user controller** simultaneously (or using the palm of your hand on a user controller featuring touch buttons). The LED will turn white.

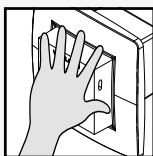

Replacing a component

1

Activate 'Installer mode' by **long-pressing 2 diagonal buttons on a paired user controller**. The LED will flash green rapidly.

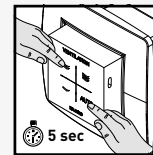

2

Press **briefly twice** on the button of the component to be replaced.

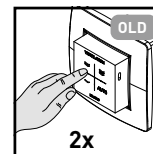

3

Tap once on the button for the new component. The latter will take on all settings / connections in the network.

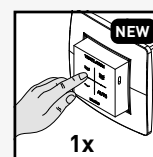

4

Deactivate 'Installer mode' by pressing the 4 buttons on a **paired user controller** simultaneously (or using the palm of your hand on a user controller featuring touch buttons). The LED will turn white.

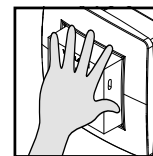

06.F Tips

Remove all components from the network (for example in case of problems):

Activate Installer mode and long press INST until the LED starts flashing red. The DucoBox will reboot (around 15 seconds) and the LED will stop flashing.

07 Air calibration

The system needs to be configured for it to work correctly. This will ensure its operation is as quiet as possible and energy-efficient. See under the Tools heading at www.duco.eu for information about determining ventilation flow rates.

07.A Air calibration procedure for DucoBox Reno



The air calibration procedure must be carried out on a calm day (no more than wind force 2: leaves rustling, feeling the wind in one's face).

Calibrating the DucoBox Reno

Set all exhaust vents so they match the desired flow rate in accordance with the table below. Proper pre-setting makes for rapid and correct calibration.

1

Flow rate	DucoVent Design	DucoVent Basic and other vents
75m ³ /h		100% open
50m ³ /h		50% open
25m ³ /h		25% open

When using DucoVent Design exhaust vents always leave the outer ring in place for acoustic effect.

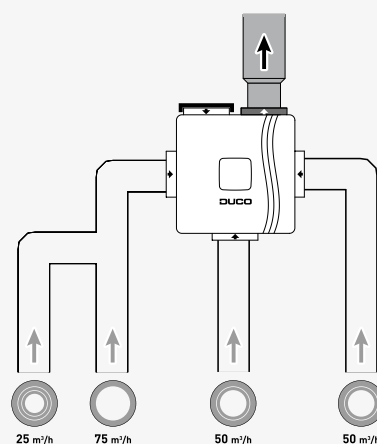
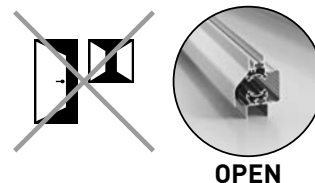

Figure 18: example situation for calibration

2

Before activating air calibration mode:

- Close **all** windows and doors.
- Ensure that **all duct openings in the DucoBox are fully closed and that the DucoBox lid is closed!**
- Avoid air leaks in the ventilation ducts.
- Set all window ventilators to the open position



Ensure that the lid of the DucoBox is properly closed. Remove the front cover with a screwdriver.

3

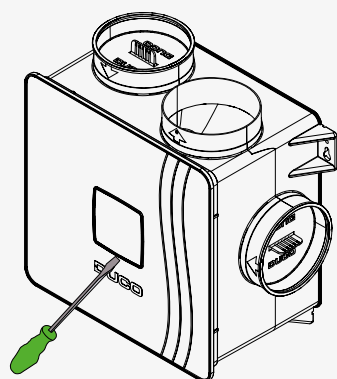

Figure 19: Remove the front cover of the lid with a screwdriver to gain access to the adjustment buttons.

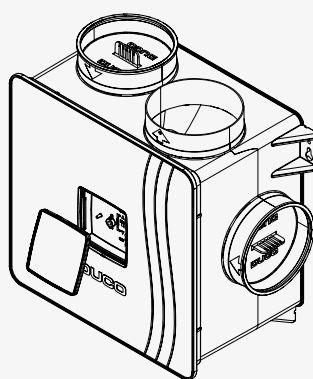

Figure 20: Removing the front cover

4 Put the DucoBox Reno into adjustment mode by pressing ▲ and ▼ together for 3 seconds until the LED next to the INST button (■) starts flashing. The adjustment mode is now activated for 30 minutes. There are 10 pre-programmed calibration curves (see figure AFTER point 10 of this chapter). The LED next to ■ flashes yellow according to a number depending on the set control curve (from 1 to 10 times). For example, 4 flashes with a pause in between stands for control curve 4 (R4).

Which configuration mode should I choose?

The LED next to the HIGH label lights up by default; the adjustment mode is set to 'HIGH'. Change the desired adjustment mode by pressing ▲ and ▼ briefly when the adjustment mode is activated. The LED display next to 'HIGH' determines the adjustment mode:

HIGH

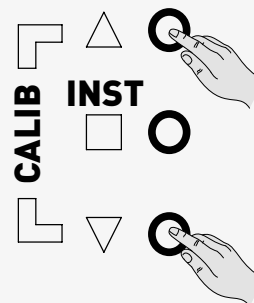

Figure 21: Selecting adjustment mode

Button	Air calibration using 'HIGH' This method is standard and has the lowest consumption. Recommended in the majority of homes.	Air calibration using 'LOW' This method offers a boost mode but may give rise to more noise and higher consumption.
	Low mode (10%)	Low mode (14-33%)
	Medium mode (50%)	High mode (100%)
	High mode (100%)	Boost mode (143-333%)
LED 'HIGH'	ACTIVE (green)	INACTIVE (off)

The percentages in the table indicate what percentage of the flow rate configured will be extracted.

The configuration mode chosen does not affect the operation of the AUTO mode.

6 Select the duct with the highest flow rate and restriction.

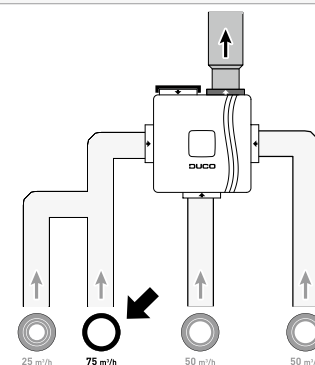

7 Measure at the vent and adjust the DucoBox's rpm until the desired flow rate is obtained. This can be done in two ways:

- Using the (lower) and (higher) buttons on a paired User Controller or Room CO₂/Humidity Sensor*.
- Using the 'DOWN' and 'UP' buttons on the DucoBox.

* Depending on the software version of the User controller.

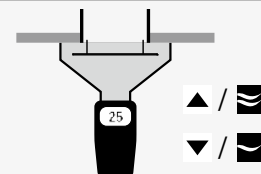

8 Now measure the other vents. **The flow rate from these other vents must only be adjusted at the vents themselves.**

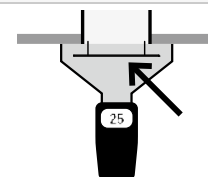

9 Repeat steps **7** and **8** until the desired flow rate has been obtained at each vent.

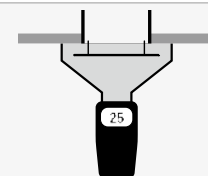

10 Exit configuration mode. To do so, press 'INST' in the DucoBox Reno.

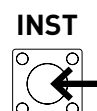

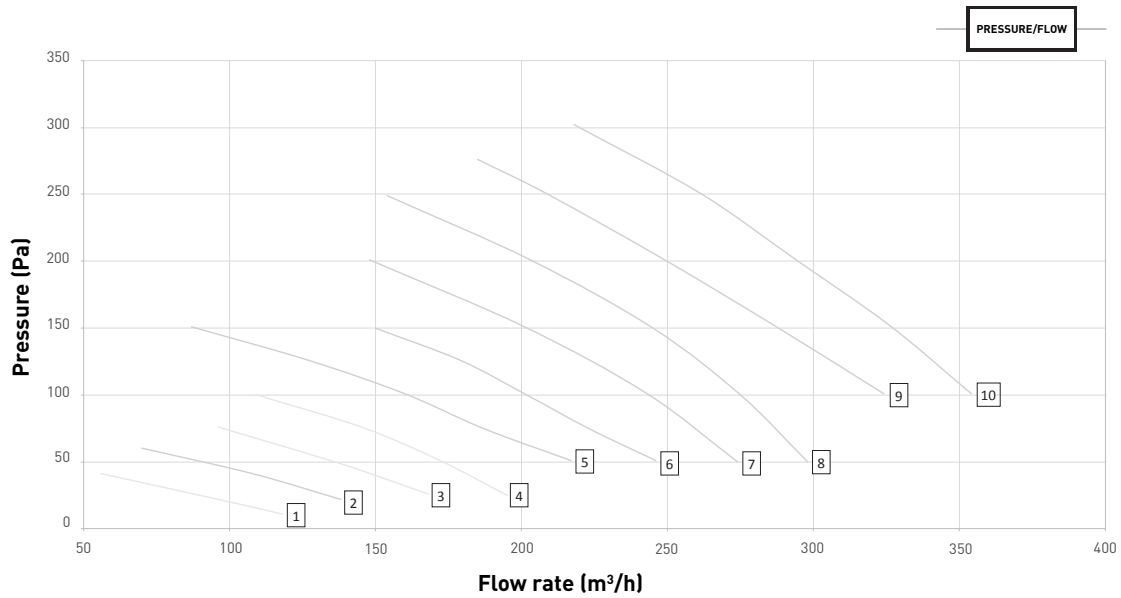

Figure 22: overview calibration curves DucoBox Reno

07.B Option: installation of user controller on the DucoBox

To keep the DucoBox and user controller together during delivery, the option is provided to mount the User controller RF/Bat on the DucoBox Reno.

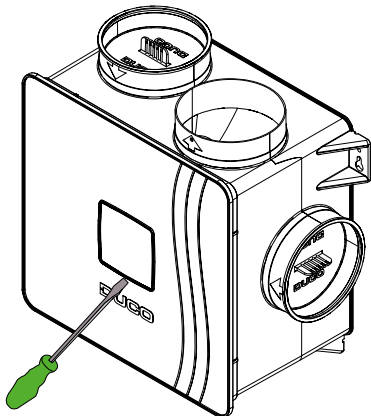

Figure 23: Remove the front cover of the lid with a screwdriver to gain access to the adjustment buttons.

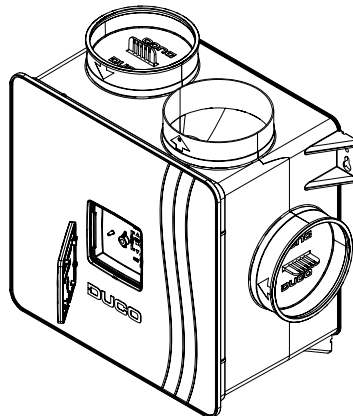

Figure 24: Turn the front cover over so that the snap-on pieces are on the outside.

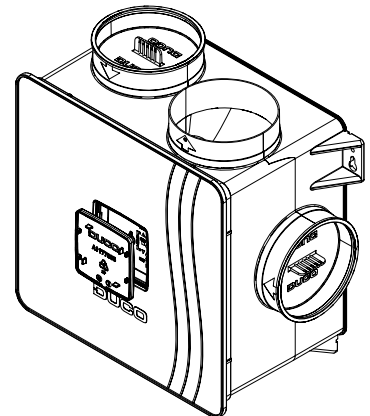

Figure 25: Mount it back on the DucoBox.

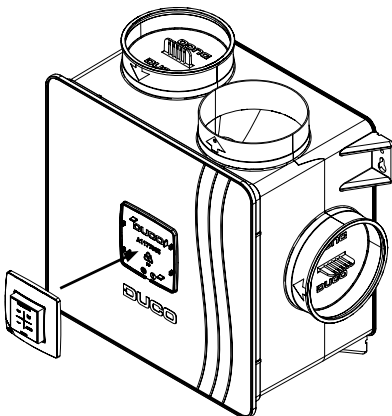

Figure 26: Snap the user controller onto the provided snap-on pieces of the front cover.

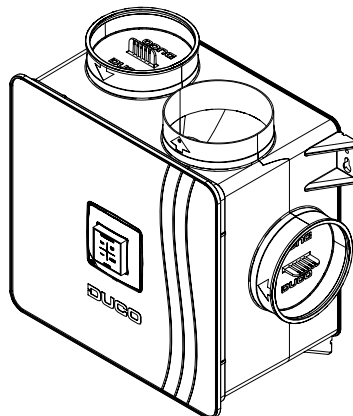



Figure 27: mounted user controller

07.C Checking

The steps set out below can be used to check whether the flow rates have been set correctly.

Checking configured flow rate

1

The configured flow rate is dependent on whether the 'HIGH' or 'LOW' configuration mode has been chosen. Press  for 'HIGH' calibration (= standard) or  for 'LOW' calibration on a random user controller to have the system run for 15 minutes at 100% of the requested flow rate.

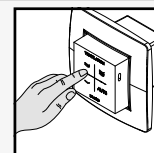
**2**

Measure the flow rate at the exhaust vents.

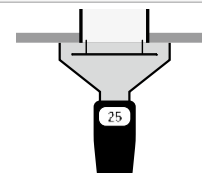
**3**

After the check, the system can be reset to the desired ventilation mode. If you do not do so, the system will automatically revert to the AUTO mode after 15 minutes.

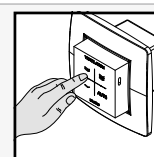

08 Maintenance & service

Please refer to the maintenance instructions [at www.duco.eu](http://www.duco.eu) and view the videos on duco.tv for more information.

For service problems as a user:

Please contact your installer. Keep the serial number of your product to hand.

For service problems as an installer:

Please contact your retailer of DUCO products. Keep the serial number of your product to hand.

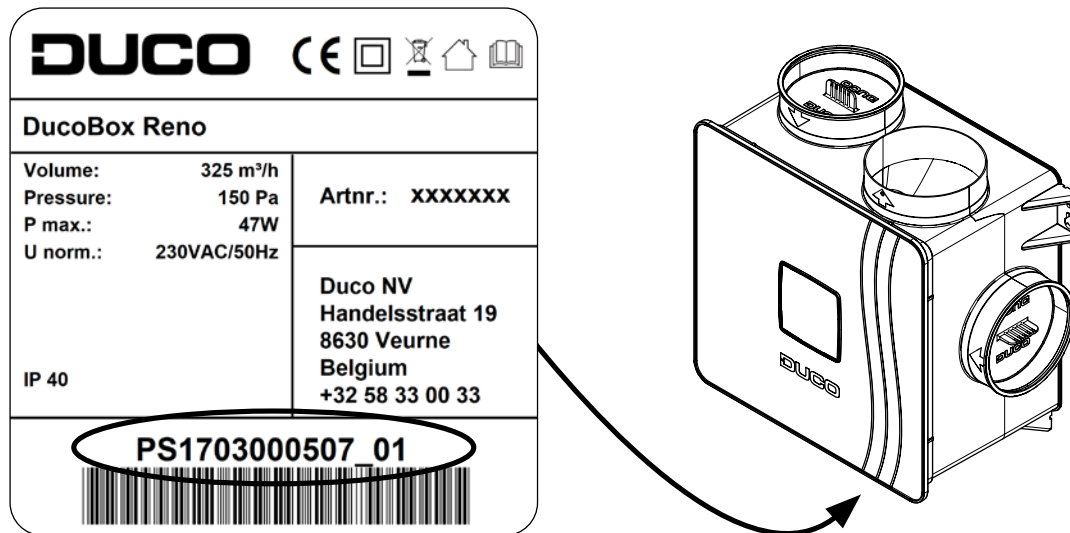

09 Warranty

All warranty conditions concerning the DucoBox and DUCO's ventilation systems can be found on the DUCO website. All complaints are to be reported to DUCO by the DUCO distributor with a clear description and the order/invoice number under which the products were delivered. To do so, please fill out the complaint registration form, found on the DUCO website, mentioning the serial number and send it to service@duco.eu.

10 Legislation

Product fiche and energy labels can be consulted and downloaded at www.duco.eu.

Simplified EU declaration of conformity



Hereby DUCO Ventilation & Sun Control declares that the radio equipment type DucoBox Reno is in compliance with Directive 2014/53/EU.

The full text of the EU declaration of conformity is available at the following internet address:
en.duco.eu/ducobox-reno

Frequency band	868,3 MHz
Maximum radio frequency power	0,4 dBm

Installed by:

DUCO